

Filterlüfter
Filter Fan

LV 800 24V, 48V



Technische Daten / Technical data:

Technische Daten / Technical data:		
Type:	LV 800	
Spannung Voltage	24 V DC	48 V DC
Stromaufnahme Amperage	5,0 A	2,6 A
Leistung Power input	105 W	
Drehzahl Speed	2750 min ⁻¹	
Temperaturbereich Temperature range	-25...+55°C	
Lebensdauer Service life	40.000 h	
Schallpegel Noise level	70 dB (A)	
Zulassung Approval	UL, CE	
Farben colours	RAL 7035 (Standard), RAL 7032	
Schutzart Degree of protection	IP 54 mit Filtermatte G3 IP 54 with Filter mat G3	
	IP 55 mit Z-Line Filter (F5) und Streckmetall, UV-beständiges Frontgitter IP 55 with Z-Line Filter (F5) and expanded metal, UV-resistant front grille	
Dichtung Gasket	aufgeschäumte Dichtung foamed gasket	
Luftfördermengen / Air flow: (m ³ /h)		
Filtermatte Filter mat	G3	Z-Line-Filter
Luftleistung freiblasend Air flow free air	650	590
mit Austrittsfilter GV 600/700 with exhaust filter	450	400
mit 2 x GV 600/700 with 2 exhaust filter	535	470

Zubehör / Accessories:

Austrittsfilter / Exhaust filter
Ersatzfiltermatte / Replacement filter mat
Thermostate / Thermostats

GV 600/700
AM 735P, AM 700P, AM 700T, ZF 600/700
TRS 60, TRW 60, TWR 60, TKW 60

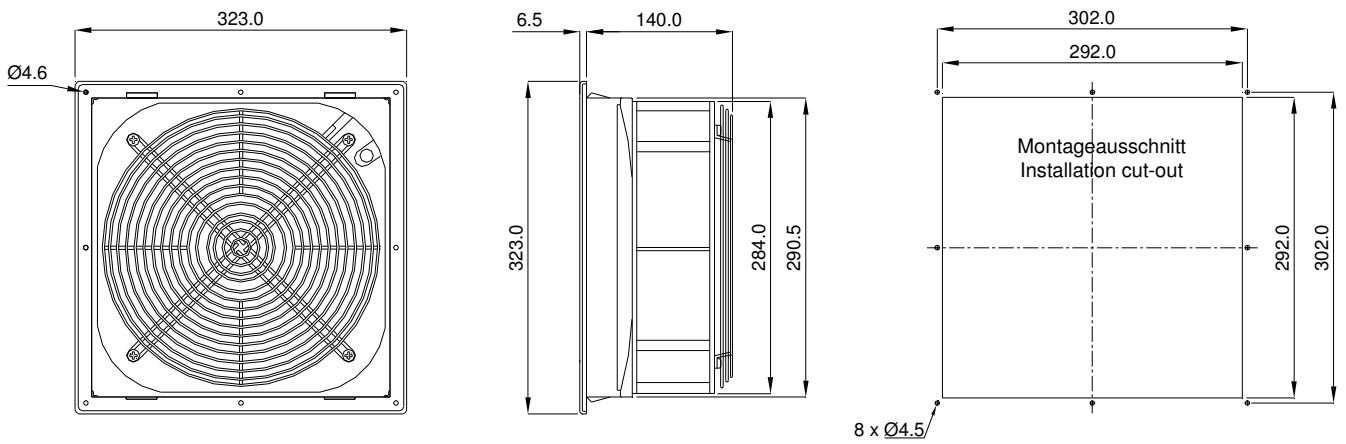

Bohrungen nur bei
Schraubbefestigung

Drill-holes are only necessary if
fan is to be fastened with screws

Leistungsdiagramm
Performance diagram

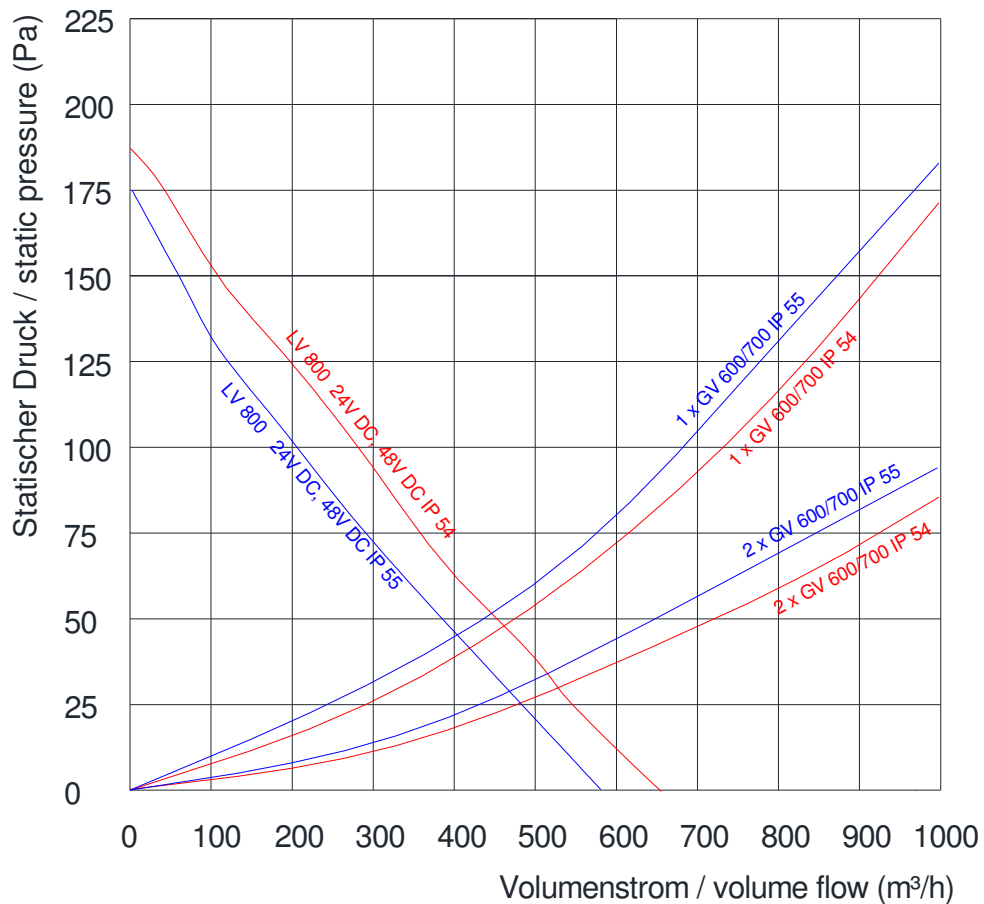

Rev. 04/16

